

CHASSIS IN COMMERCIAL VEHICLES

FROM A LADDER FRAME
TO MODULAR CHASSIS
STRUCTURES

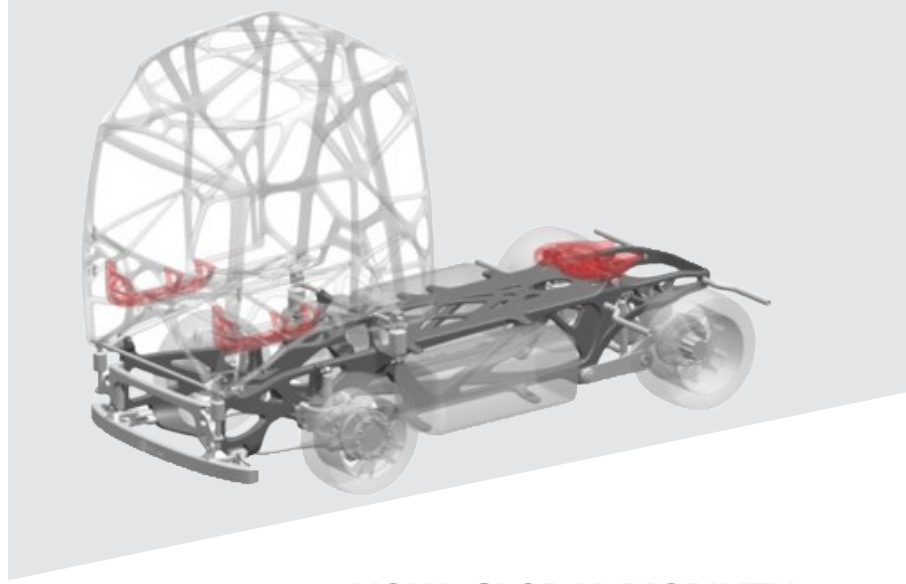

**YOUR GLOBAL MOBILITY
ENGINEERING EXPERTS**

The **COMMERCIAL & OFFROAD VEHICLE BUSINESS UNIT**, one of the **EDAG Group's** specialist departments, covers the complete development spectrum for the development of conventional and electric-powered commercial vehicles. In several hundred projects with varying degrees of complexity, the development team has established its position in international commercial vehicle industry.

As well as developing **components, modules and complete vehicles**, we also manufacture **prototype parts and vehicles**, which we subsequently validate, either using our own **test systems** or in **test mode at test centres**.

With our high degree of **flexibility** and **outstanding engineering quality** - and not least because we speak the **language of the commercial vehicle industry** - we have developed into one of the leading engineering partners in the commercial vehicle sector.

We will be happy to assist you with the efficient execution of future challenges and projects.

Contact our experts direct:
E-Mail: commercialvehicle@edag.com

Our services for the commercial vehicle industry:

- Project management
- Complete vehicle concepts for the international market
- Lightweight design and modular chassis structures
- Integration of conventional or alternative powertrains
- Development/design in the fields of special-purpose vehicles, trailers and passenger transport
- Integration of additional steered and liftable axles
- Documentation in the customer's PDM systems
- Prototype construction, low-volume engineering and testing

